



Denver International Airport

Noise Abatement Office Annual Report – 2000

Includes 2000 Quarterly Breakdown

Please Note: Does not include the impact of extraordinary weather to the NEPS Values.

Introduction

This report is published by the DIA Noise Abatement Office as part of DIA's commitment to minimize noise impacts in the airport environs. Although the Federal Aviation Administration (FAA) is the sole authority for the control of aircraft, the City and County of Denver, as airport proprietor, has taken the lead responsibility for monitoring and addressing DIA aircraft noise issues in the vicinity of the airport.

The focus of this report is on the data collected by DIA's Airport Noise and Operations Monitoring System (ANOMS) throughout 2000. In addition to annual data, a breakdown by quarter is also provided. Information contained in this publication includes Noise Exposure Performance Standards (NEPS) values, maps depicting DIA's 65 Ldn noise contour, as well as aircraft operations statistics, and runway use percentages. For a complete description of DIA's ANOMS system see page 3.

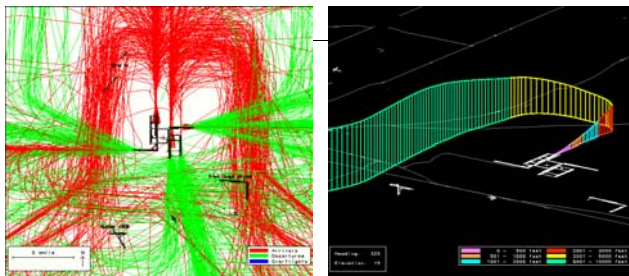

Examples of ANOMS System Output



Aircraft flying over an RMT



FAA Airport Surveillance Radar

- *The Noise Contours and NEPS values were established pursuant to DIA operating with 6 runways. Currently DIA has only 5 operating runways, therefore the reported data may be inconsistent with established numeric sound levels for the Noise Contour and NEPS locations.*

Contents

Introduction	1
NEPS Points and RMT Maps	2
DIA ANOMS System	3
2000 Annual Data	4
First Quarter 2000 Data	9
Second Quarter 2000 Data	13
Third Quarter 2000 Data	17
Fourth Quarter 2000 Data	21

Definitions

- **Contour** – A line enclosing a certain area in which the annual Ldn is at or above a certain level.
- **dB** – Decibel. A Linear scale used to define a logarithmic scale of sound amplification.
- **Ldn** – A 24 hour Leq with a 10 dB penalty added to all levels measured between 10pm and 7am.
- **Leq** – Equivalent continuous sound level (average level over a given time span)
- **NEPS** – Noise Exposure Performance Standards. A group of geographic points surrounding DIA, for which corresponding annual aircraft Leq limits have been set in the IGA. There are 101 grid points in Adams County defined in the IGA. (See map page 2)
- **Area 1:** Brighton and Barr Lake
- **Area 2:** Thornton, Northglenn and Commerce City
- **Area 3:** Aurora

Please Note: Does not include the impact of extraordinary weather to the NEPS Values.

Noise Exposure Performance Standards (NEPS) Grid Coordinates

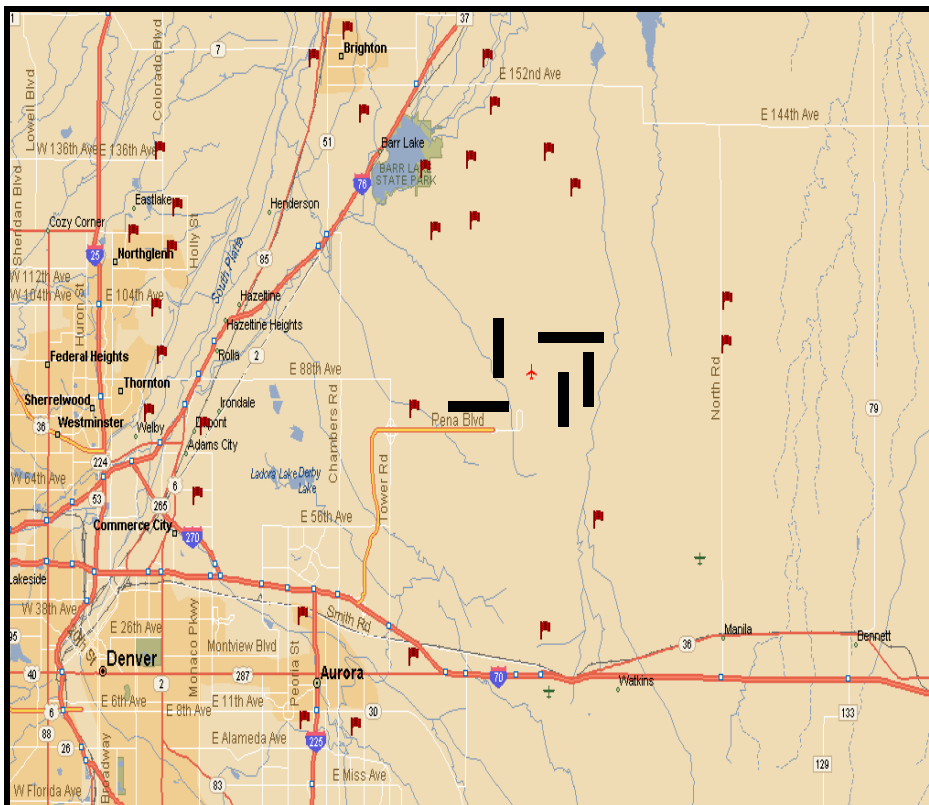
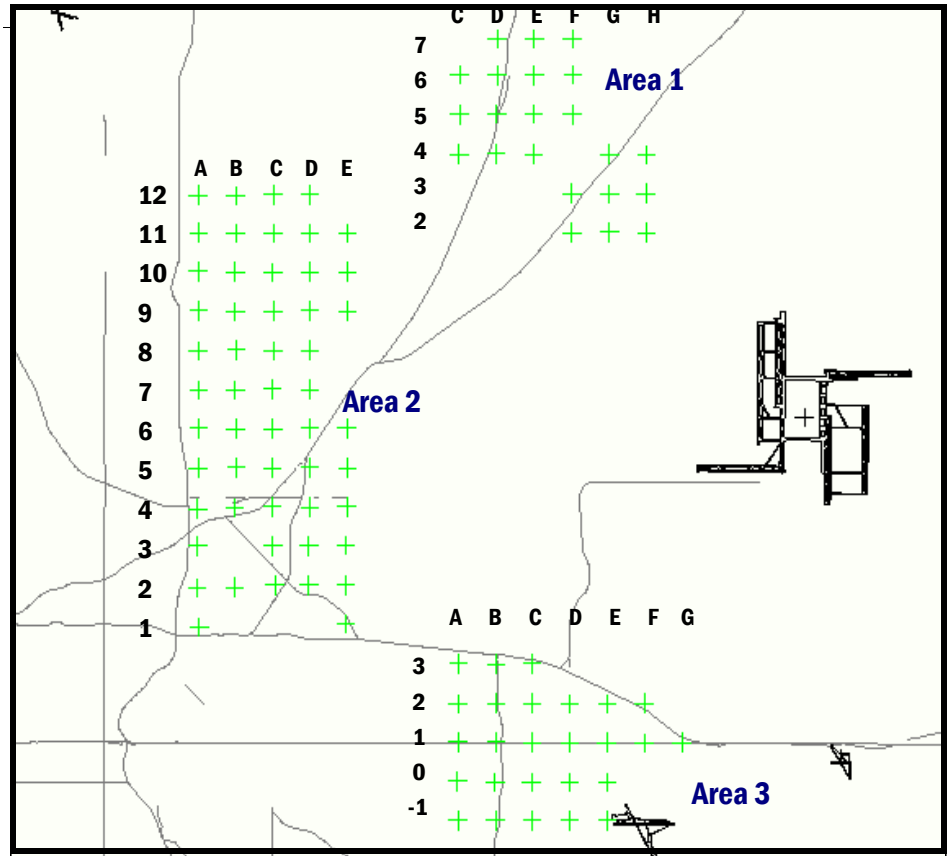

Remote Monitoring Terminal (RMT) Locations

DIA – Airport Noise and Operations Monitoring System

The Denver International Airport – Airport Noise and Operations Monitoring System (AMOMS) is a state-of-the-art computer system designed to enable the City and County of Denver to monitor aircraft noise in the vicinity of the airport. In addition to monitoring noise levels, the system calculates Noise Exposure performance Standards (NEPS) at 101 grid points in Adams County (see map page 2).

The DIA ANOMS system monitors noise levels at 28 permanent and 4 portable noise monitoring terminals. These terminals are located throughout the metro Denver area.

The system also records the movement of all aircraft in the vicinity of DIA by utilizing FAA air traffic control radar data. This makes it possible to match actual flights with noise events. In addition the ANOMS system records weather info from three remote stations and includes a RACAL recording device to record pilot/controller radio transmissions.



DIA Noise Hotline Policy

The purpose of the DIA noise hotline is to provide an opportunity for individuals to express their concerns regarding noise generated by aircraft operating at DIA. The noise complaint system has been designed to ask questions relative to citizens' concerns. Once this information has been correctly entered, it is then transcribed into the Airport Noise and Operations Monitoring System (ANOMS), where specific complaints can be matched to individual flight tracks. It is essential for all information to be entered correctly in order for the system to be effective.

Profanity will not be tolerated and will result in the complaint not being registered.

Any attempt to deliberately tie-up or abuse the hotline can be considered harassment and may result in police action. Phone harassment is a state offense and can carry a jail sentence and/or fines. ***Threats involving aircraft and/or the airport are a very serious matter and are a federal offense. All threats will result in Denver Police Department notification and may involve an FBI investigation.***

Please note that the noise hotline is an automated system, and that weak or noisy telephone lines in a caller's local area may in some rare cases cause the system to disconnect or malfunction. We have therefore created two alternate methods which may be used to register a complaint. Complaints may be faxed to (303) 342-2366, or E-mailed to Noise.Office@diadenver.net.

DIA Noise Abatement Office
Airport Office Building
8500 Peña Blvd.
Denver, Colorado 80249
Noise Complaint Hotline: (303) 342-2380
Toll Free (Outside of local calling area): 1-800-417-2988
Fax: (303) 342-2366
E-mail: Noise.Office@diadenver.net

Annual 2000

March 1, 2000– February 28, 2001

2000 Annual 65Ldn Contour

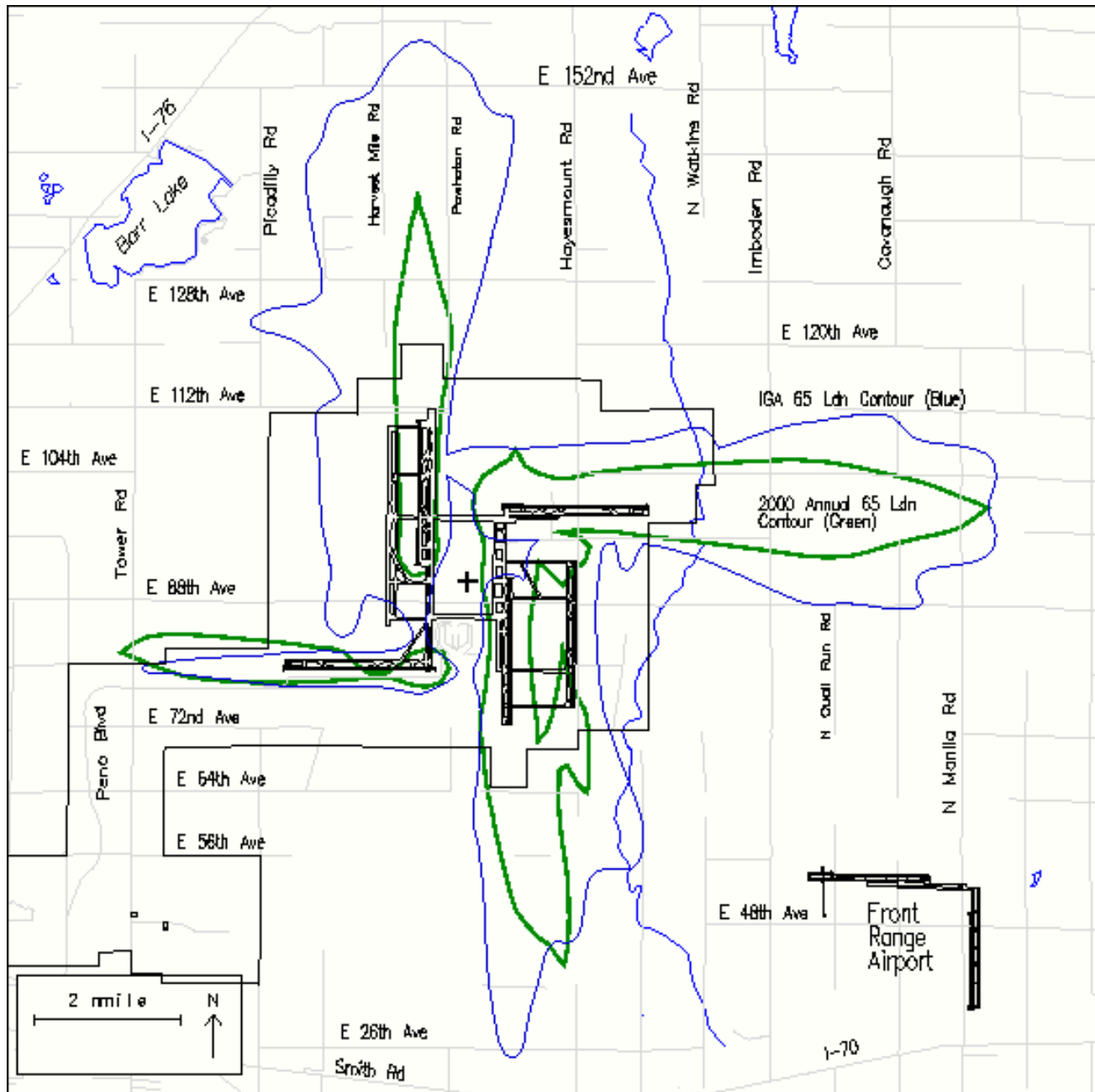

Denver/Adams County IGA NEPS Values – 2000 Annual

Area 2				Area 1			
Grid Points	2000 Annual		Difference	Grid Points	2000 Annual		Difference
	IGA Annual Leq (24)	Calculated Leq (24)			IGA Annual Leq (24)	Calculated Leq (24)	
A,1	38.6	39.7	1.1	C,4	44.2	40.8	-3.4
A,2	37.6	40.5	2.9	C,5	36.7	38.2	1.5
A,3	42.3	41.5	-0.8	C,6	36.0	36.6	0.6
A,4	45.3	42.6	-2.7	D,4	41.1	39.5	-1.6
A,5	43.9	44.1	0.2	D,5	34.2	37.2	3.0
A,6	37.5	45.2	7.7	D,6	36.0	36.1	0.1
A,7	37.7	45.2	7.5	D,7	41.4	37.6	-3.8
A,8	36.5	43.0	6.5	E,4	38.3	39.9	1.6
A,9	36.3	40.5	4.2	E,5	34.8	39.3	4.5
A,10	37.6	39.8	2.2	E,6	36.7	37.0	0.3
A,11	39.2	39.1	-0.1	E,7	41.4	37.0	-4.4
A,12	41.2	38.4	-2.8	F,2	51.7	46.9	-4.8
B,2	39.5	41.2	1.7	F,3	43.7	44.0	0.3
B,4	42.5	43.2	0.7	F,5	37.3	38.8	1.5
B,5	43.1	44.8	1.7	F,6	38.5	38.3	-0.2
B,6	39.0	46.1	7.1	F,7	42.1	38.4	-3.7
B,7	39.0	45.8	6.8	G,2	51.2	48.7	-2.5
B,8	38.0	43.0	5.0	G,3	42.1	44.9	2.8
B,9	38.3	41.0	2.7	G,4	40.2	40.8	0.6
B,10	39.0	40.7	1.7	H,2	50.1	50.6	0.5
B,11	40.4	40.3	-0.1	H,3	46.0	45.8	-0.2
B,12	42.6	39.6	-3.0	H,4	46.1	41.8	-4.3
C,2	41.0	42.2	1.2	Area 3			
C,3	43.3	43.2	-0.1			2000 Annual	
C,4	43.5	44.1	0.6	Grid Points	IGA Annual Leq (24)	Calculated Leq (24)	Difference Leq
C,5	43.4	45.7	2.3	A,-1	38.9	36.5	-2.4
C,6	43.3	47.3	4.0	A,0	39.6	36.6	-3.0
C,7	43.3	46.3	3.0	A,1	43.2	37.2	-6.0
C,8	42.6	43.2	0.6	A,2	45.7	38.5	-7.2
C,9	42.2	42.0	-0.2	A,3	45.6	39.9	-5.7
C,10	41.6	42.1	0.5	B,-1	37.9	36.1	-1.8
C,11	42.5	41.6	-0.9	B,0	39.2	36.0	-3.2
C,12	44.3	40.9	-3.4	B,1	42.6	36.6	-6.0
D,2	41.7	42.9	1.2	B,2	45.8	38.0	-7.8
D,3	46.2	44.1	-2.1	B,3	45.7	39.8	-5.9
D,4	48.4	45.1	-3.3	C,-1	36.7	36.3	-0.4
D,5	48.2	46.7	-1.5	C,0	37.1	36.1	-1.0
D,6	46.2	48.5	2.3	C,1	39.5	36.6	-2.9
D,7	44.2	46.8	2.6	C,2	44.8	37.9	-6.9
D,8	43.7	43.6	-0.1	C,3	46.5	40.1	-6.4
D,9	43.1	43.5	0.4	D,-1	32.6	36.6	4.0
D,10	44.9	43.3	-1.6	D,0	33.3	36.5	3.2
D,11	44.5	42.6	-1.9	D,1	37.3	37.2	-0.1
D,12	45.1	41.8	-3.3	D,2	43.0	38.2	-4.8
E,1	42.4	42.5	0.1	E,-1	31.4	36.9	5.5
E,2	42.2	43.6	1.4	E,0	33.1	36.8	3.7
E,3	46.7	45.2	-1.5	E,1	36.2	37.3	1.1
E,4	51.2	46.3	-4.9	E,2	40.6	38.1	-2.5
E,5	51.0	47.9	-3.1	F,1	36.5	37.4	0.9
E,6	44.6	49.9	5.3	F,2	39.4	38.7	-0.7
E,9	43.1	45.1	2.0	G,1	42.5	38.0	-4.5
E,10	43.1	44.0	0.9				
E,11	46.1	43.0	-3.1				

Please Note: Does **not** include the impact of extraordinary weather to the NEPS Values.

2000 Annual Complaint Statistics

Number of complaints	2000	1999
Total number of noise complaints	15,500	14,668
Total number of hotline callers/households	992/876	585/559
Max # of complaints by an individual/household	4456/4456	2007/2007

Breakdown by time of day	2000	%	1999	%
Day hours (7 a.m. - 9:59p.m.)	13,147	84.8%	12,883	87.8%
Night Hours (10 p.m. - 6:59 a.m.)	2,353	15.2%	1,785	12.2%
All Hours	15,500	100.0%	14,668	100.0%

Breakdown by Month					
1st Quarter	2nd Quarter	3rd Quarter	4th Quarter		
March 779	June 988	September 859	December 1493		
April 754	July 1411	October 1988	January 1720		
May 1040	August 1492	November 1296	February 1680		
2,573	3,891	4,143	4,893		

Total Complaints

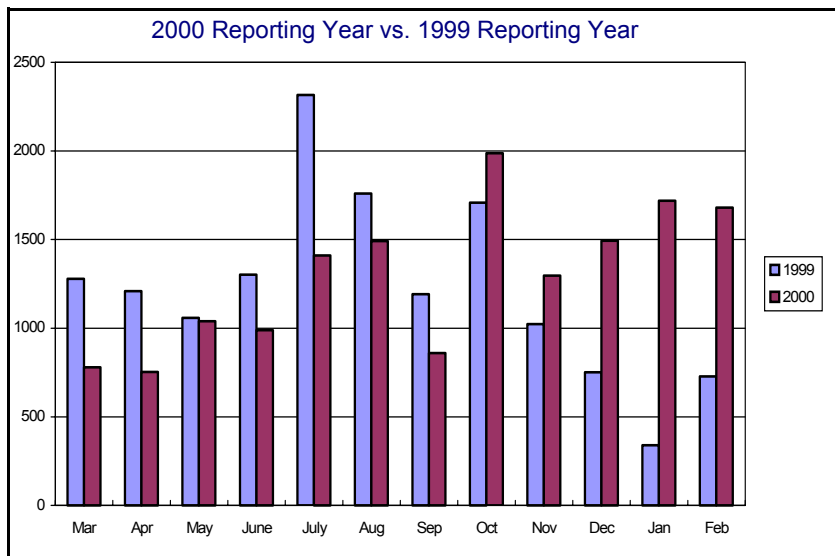

Monthly Aircraft Operations*

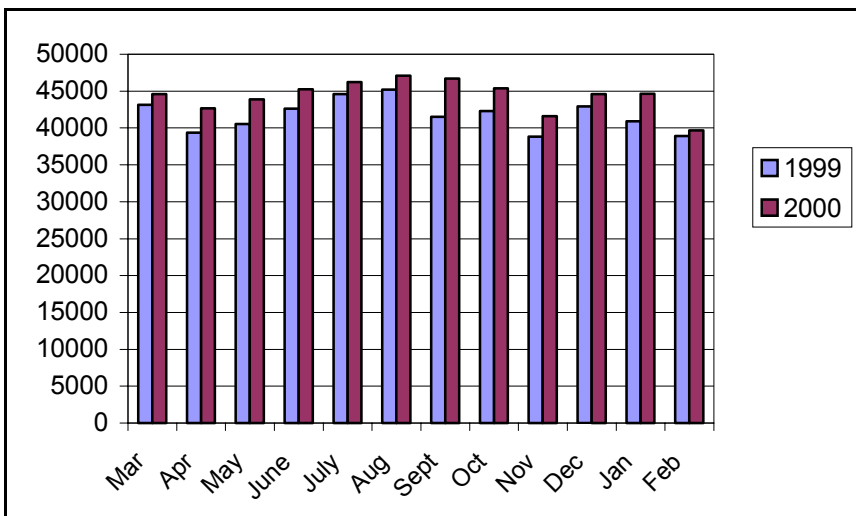

City	City Total	Households	Max #*
Blank	160	15	20
Arvada	32	2	27
Aurora	439	56	133
Bennett	19	3	14
Black Hawk	1	1	1
Boulder	1740	50	970
Brighton	519	38	300
Broomfield	5	3	3
Byers	2	2	1
Castle Rock	1	1	1
Commerce City	146	15	80
Conifer	1	1	1
Denver	271	54	91
Elizabeth	1439	24	939
Englewood	3	2	2
Estes Park	3	1	3
Evergreen	489	4	483
Fort Collins	28	1	28
Franktown	18	6	11
Golden	40	7	9
Henderson	1	1	1
Highlands Ranch	8	4	5
Hudson	8	3	6
Keesburg	4	2	2
Kiowa	4	2	3
Lafayette	2	2	1
Lakewood	1146	6	1076
Larkspur	3	2	2
Littleton	4	3	3
Longmont	6	2	5
Louisville	224	4	182
Louivers	44	1	44
Lyons	4	3	2
Morrison	24	2	23
Nederland	5705	29	3810
Northglenn	27	13	8
Parker	1310	44	729
Sedalia	5	1	5
Superior	56	1	56
Thornton	581	79	155
Watkins	120	7	55
Westminster	851	15	494
Wheatridge	7	1	7
Total	15500	513	

* This column further breaks down the household category by depicting the highest number of complaints received from an individual household.

Top 10 Complainants vs. All Others

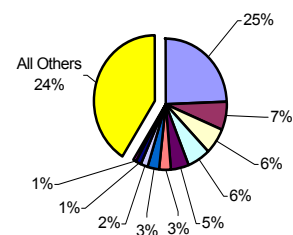

*Total Operations: includes Air Carrier, General Aviation and Air Taxi Source: Federal Aviation Administration

Runway Utilization – 2000 Annual

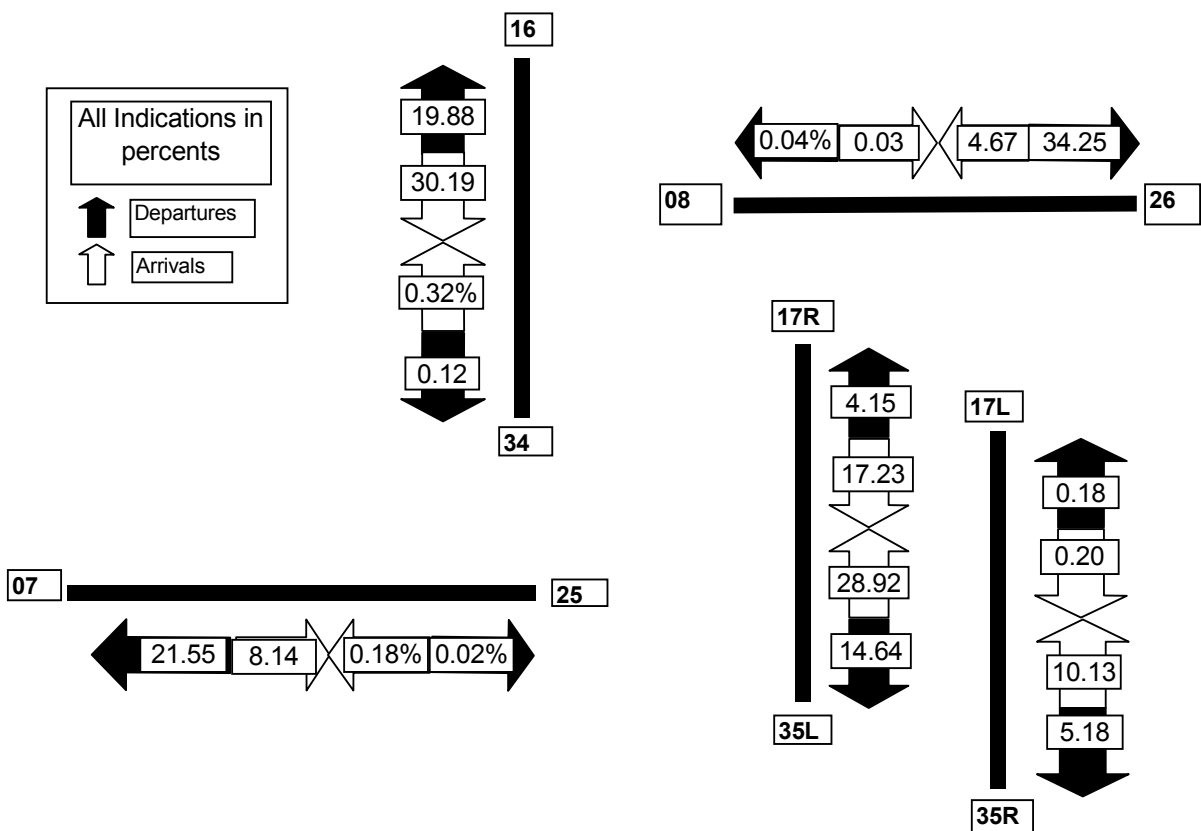

Day Arrivals (700am-959pm)

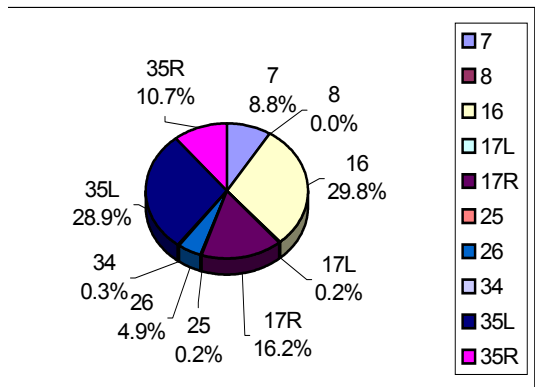

Day Departures (700am-959pm)

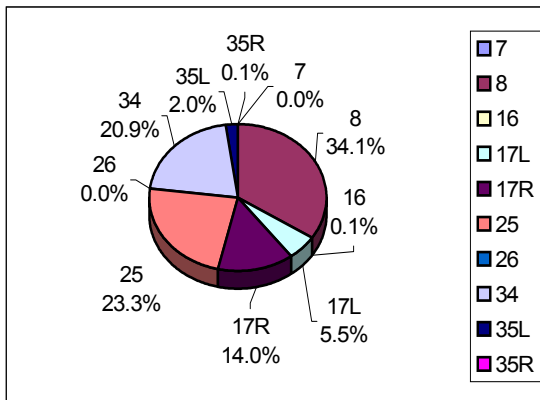

Night Arrivals (1000pm-659am)

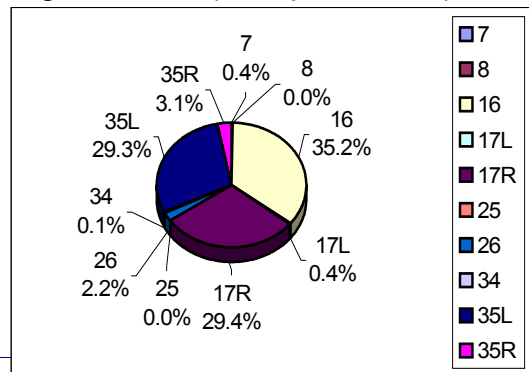

Night Departures (1000pm-659am)

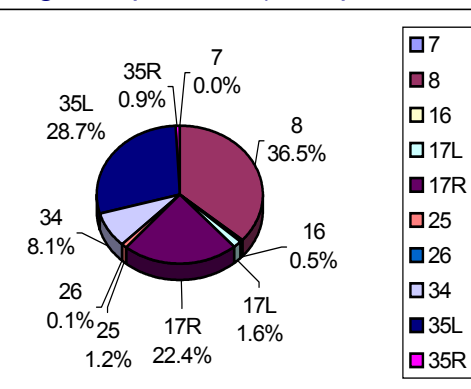

First Quarter, 2000
March 1, 2000 – May 31, 2000

First Quarter 2000 65 Ldn Contour

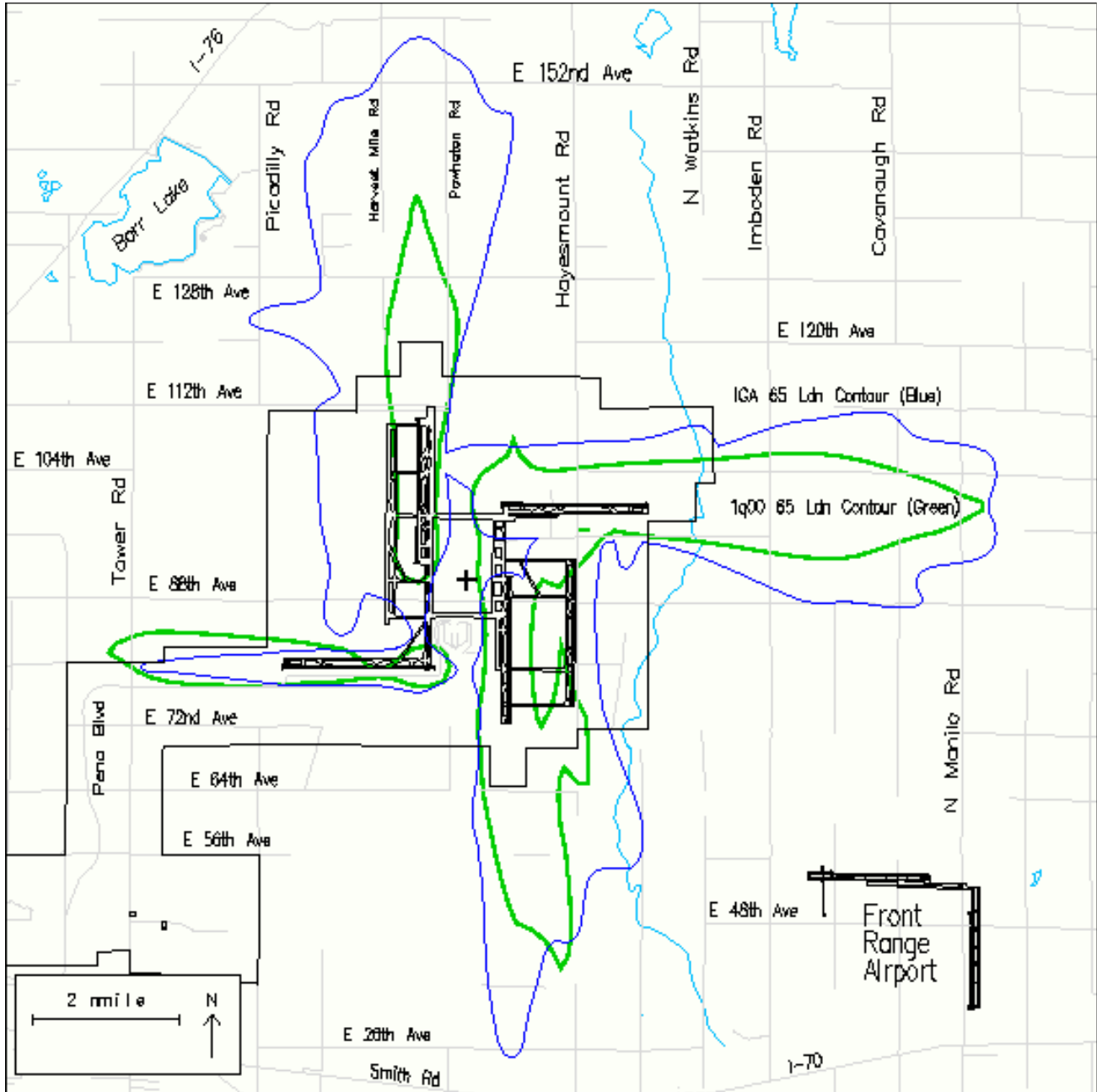

Denver/Adams County IGA NEPS Values – First Quarter 2000

Area 2				Area 1			
Grid Points	1st Quarter		Difference	Grid Points	1st Quarter		Difference
	IGA Annual Leq (24)	Calculated Leq (24)			IGA Annual Leq (24)	Calculated Leq (24)	
A,1	38.6	39.1	0.5	C,4	44.2	40.4	-3.8
A,2	37.6	39.9	2.3	C,5	36.7	37.7	1.0
A,3	42.3	41.0	-1.3	C,6	36.0	36.5	0.5
A,4	45.3	42.1	-3.2	D,4	41.1	39.2	-1.9
A,5	43.9	43.4	-0.5	D,5	34.2	36.8	2.6
A,6	37.5	44.4	6.9	D,6	36.0	36.1	0.1
A,7	37.7	44.4	6.7	D,7	41.4	38.0	-3.4
A,8	36.5	42.4	5.9	E,4	38.3	40.0	1.7
A,9	36.3	40.2	3.9	E,5	34.8	39.3	4.5
A,10	37.6	39.4	1.8	E,6	36.7	37.1	0.4
A,11	39.2	38.6	-0.6	E,7	41.4	37.3	-4.1
A,12	41.2	37.6	-3.6	F,2	51.7	46.5	-5.2
B,2	39.5	40.8	1.3	F,3	43.7	43.7	0.0
B,4	42.5	42.8	0.3	F,5	37.3	38.4	1.1
B,5	43.1	44.3	1.2	F,6	38.5	38.2	-0.4
B,6	39.0	45.4	6.4	F,7	42.1	38.5	-3.6
B,7	39.0	45.1	6.1	G,2	51.2	48.5	-2.7
B,8	38.0	42.4	4.4	G,3	42.1	44.5	2.4
B,9	38.3	40.6	2.3	G,4	40.2	40.8	0.6
B,10	39.0	40.3	1.3	H,2	50.1	50.3	0.2
B,11	40.4	39.7	-0.7	H,3	46.0	45.3	-0.7
B,12	42.6	38.8	-3.8	H,4	46.1	41.7	-4.4
C,2	41.0	42.1	1.1	Area 3			
C,3	43.3	42.7	-0.6	1st Quarter			
C,4	43.5	43.6	0.1	Grid Points	IGA Annual Leq (24)	Calculated Leq (24)	Difference Leq
C,5	43.4	45.2	1.8	A,-1	38.9	36.9	-2.1
C,6	43.3	46.6	3.3	A,0	39.6	36.9	-2.7
C,7	43.3	45.6	2.3	A,1	43.2	37.3	-5.9
C,8	42.6	42.5	-0.1	A,2	45.7	38.1	-7.6
C,9	42.2	41.4	-0.8	A,3	45.6	39.1	-6.6
C,10	41.6	41.4	-0.2	B,-1	37.9	36.6	-1.3
C,11	42.5	40.9	-1.6	B,0	39.2	36.4	-2.8
C,12	44.3	39.9	-4.4	B,1	42.6	37.0	-5.6
D,2	41.7	43.1	1.4	B,2	45.8	37.7	-8.1
D,3	46.2	44.0	-2.2	B,3	45.7	38.7	-7.0
D,4	48.4	44.7	-3.7	C,-1	36.7	36.7	0.0
D,5	48.2	46.4	-1.8	C,0	37.1	36.2	-0.9
D,6	46.2	47.8	1.6	C,1	39.5	36.8	-2.7
D,7	44.2	46.0	1.8	C,2	44.8	37.3	-7.5
D,8	43.7	43.0	-0.7	C,3	46.5	38.7	-7.8
D,9	43.1	42.6	-0.5	D,-1	32.6	36.8	4.2
D,10	44.9	42.5	-2.4	D,0	33.3	36.4	3.1
D,11	44.5	41.8	-2.7	D,1	37.3	37.1	-0.2
D,12	45.1	40.8	-4.3	D,2	43.0	37.4	-5.6
E,1	42.4	43.1	0.7	E,-1	31.4	37.0	5.6
E,2	42.2	44.3	2.1	E,0	33.1	36.9	3.8
E,3	46.7	45.5	-1.3	E,1	36.2	37.4	1.2
E,4	51.2	45.9	-5.3	E,2	40.6	37.7	-2.9
E,5	51.0	47.6	-3.4	F,1	36.5	37.6	1.1
E,6	44.6	49.2	4.6	F,2	39.4	38.3	-1.1
E,9	43.1	44.2	1.1	G,1	42.5	38.1	-4.4
E,10	43.1	43.4	0.3	G,1	42.5	38.1	-4.4
E,11	46.1	42.2	-3.9				

Runway Utilization – 1st Quarter 2000

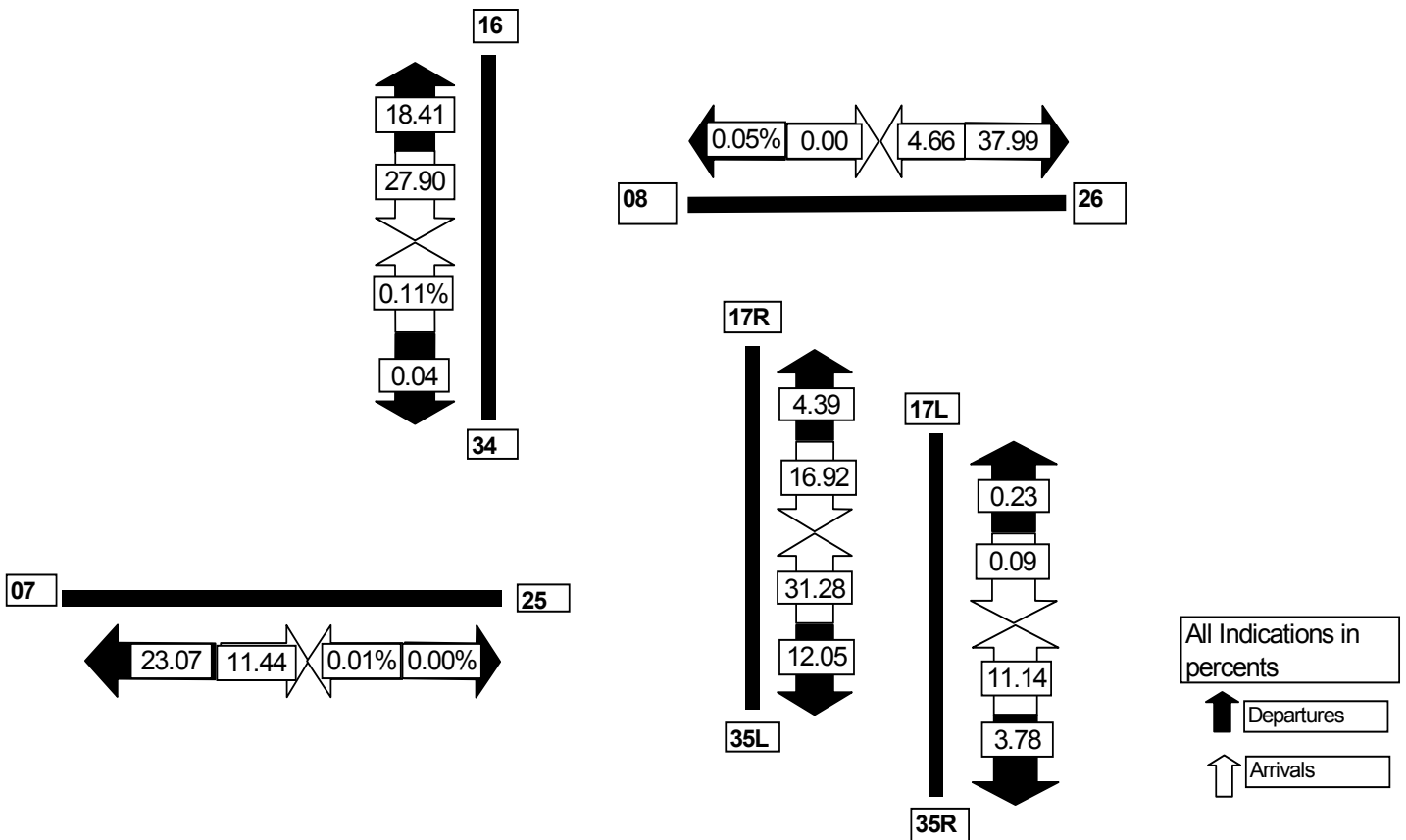

Day Arrivals (700am-959pm)

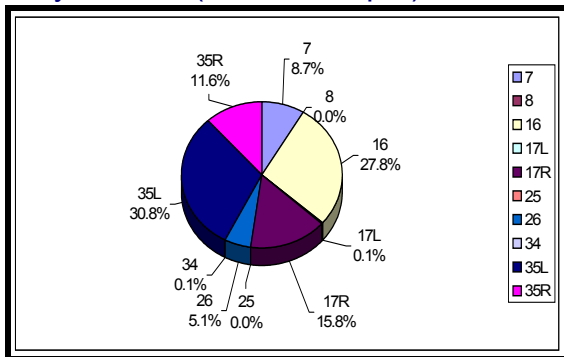

Day Departures (700am-959pm)

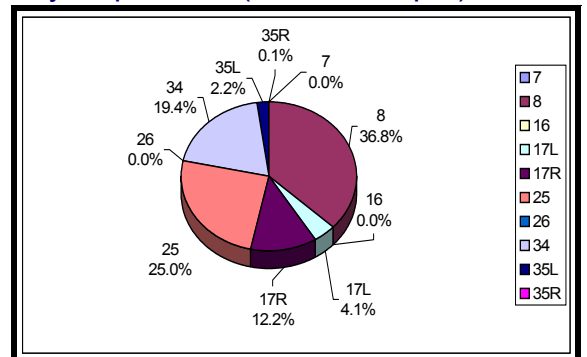

Night Arrivals (1000pm-659am)

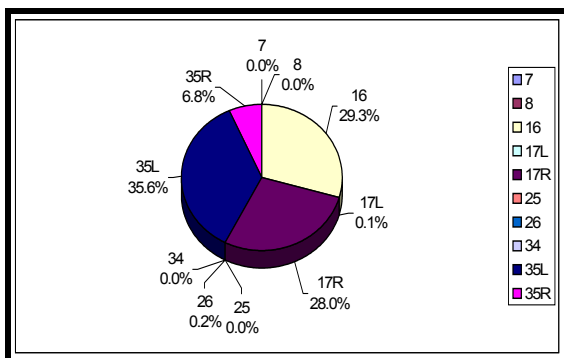

Night Departures (1000pm-659am)

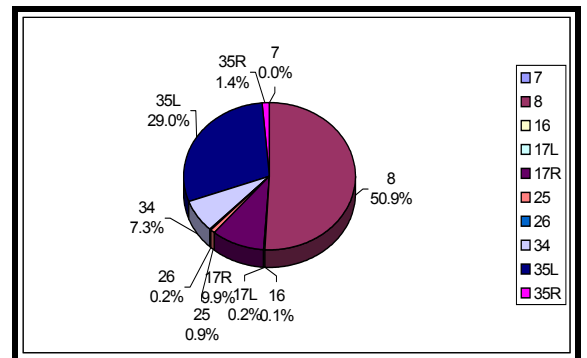

Second Quarter, 2000
June 1, 2000 – August 31, 2000

Second Quarter 2000 65 Ldn Contour

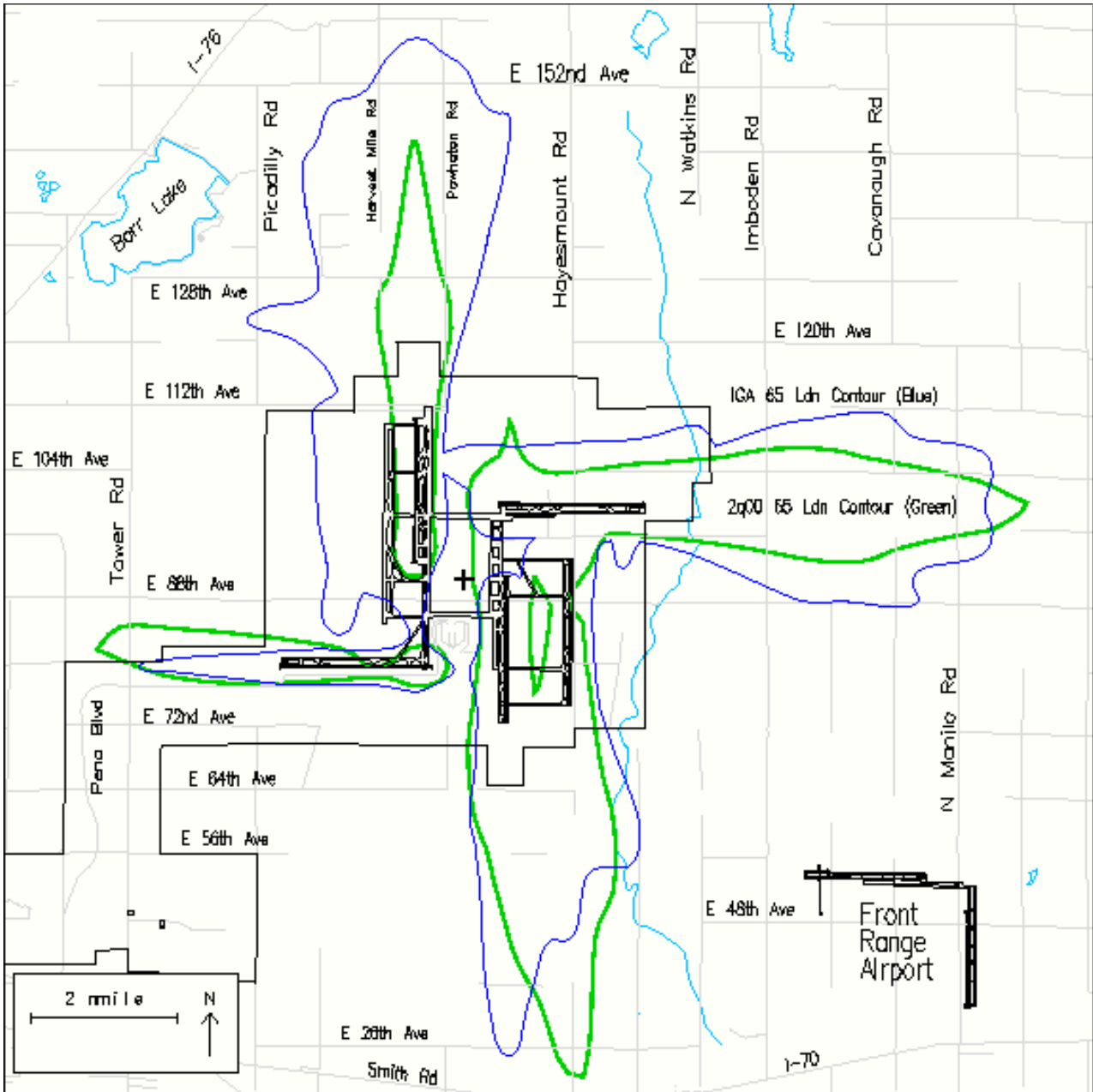

Denver/Adams County IGA NEPS Values – Second Quarter 2000

**No Data
Available**

Runway Utilization - 2nd Quarter 2000

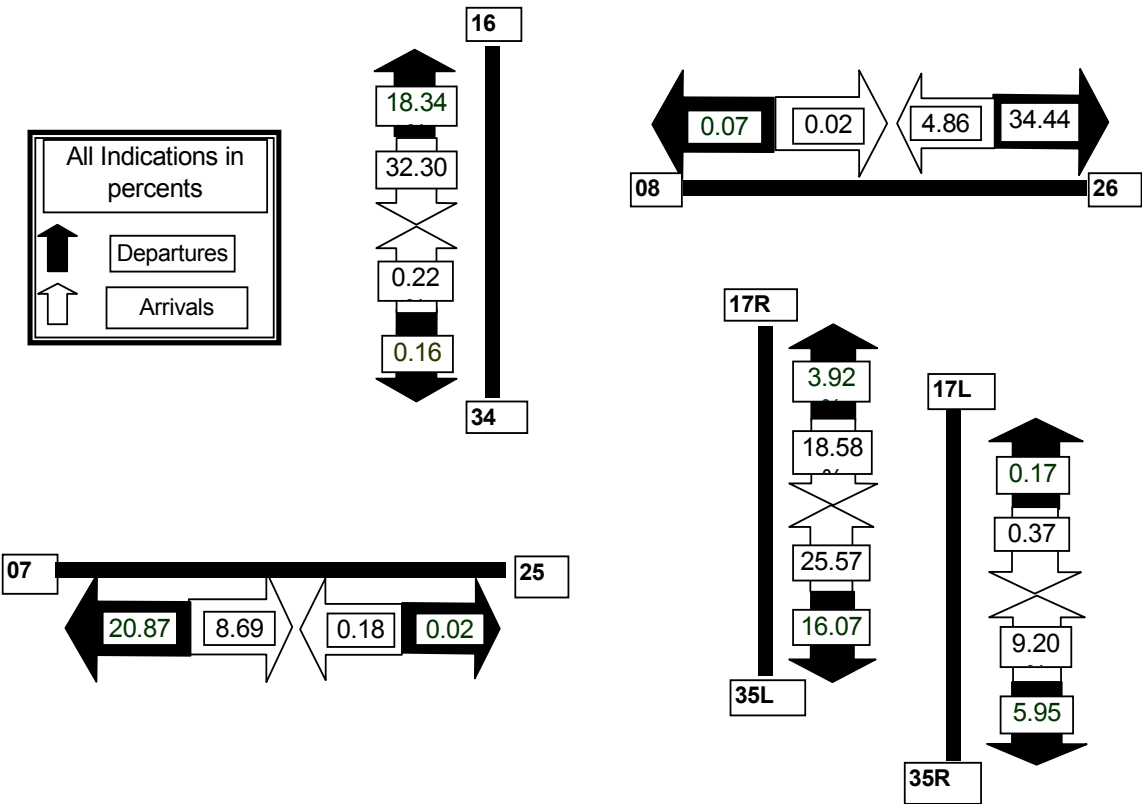

Day Arrivals (700am-959pm)

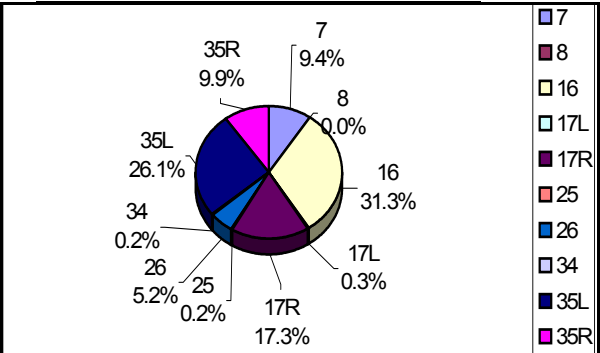

Day Departures (700am-959pm)

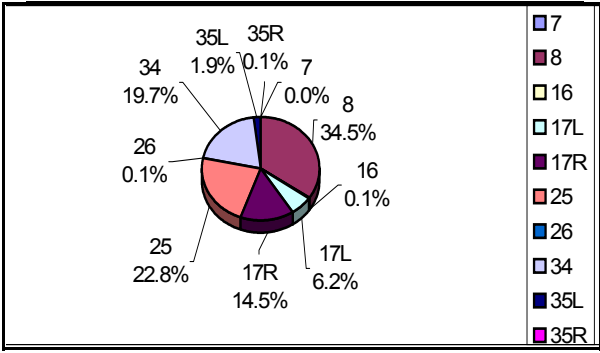

Night Arrivals (1000pm-659am)

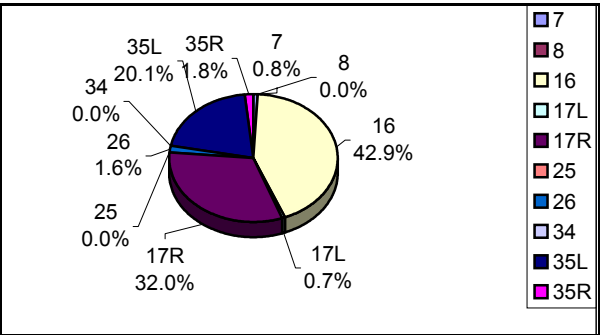

Night Departures (1000pm-659am)

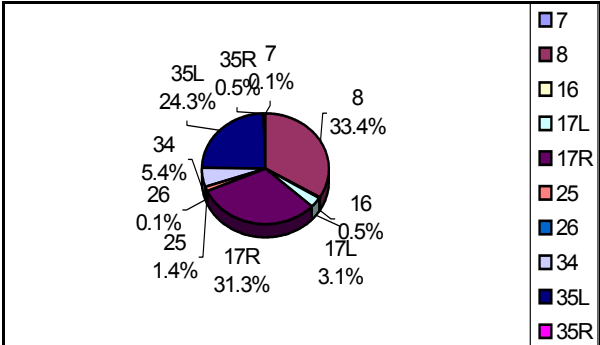

Third Quarter, 2000
September 1, 2000 – November 30, 2000

Third Quarter 2000 65 Ldn Contour

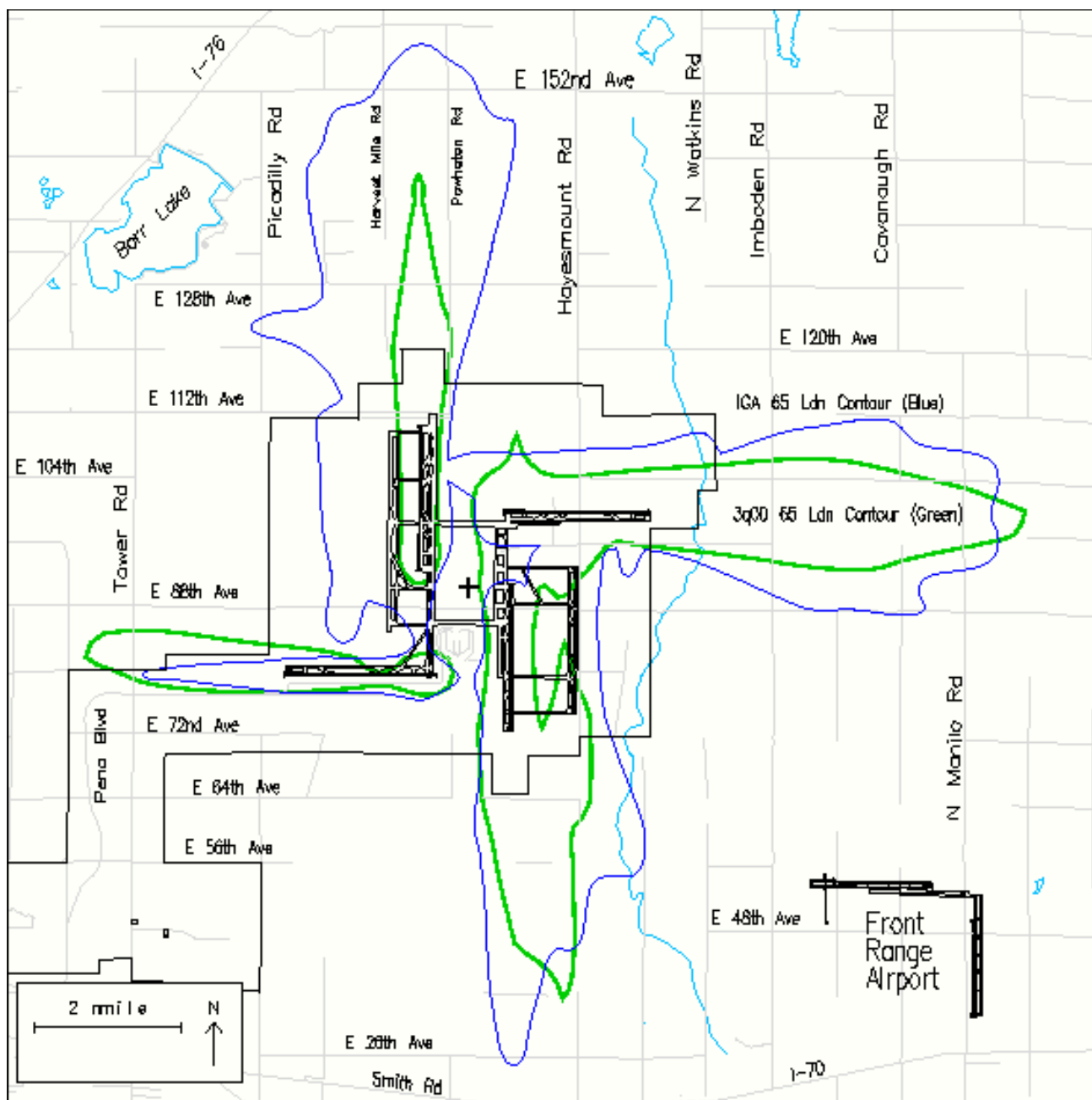

Denver/Adams County IGA NEPS Values – Third Quarter 2000

Area 2 3rd Quarter				Area 1 3rd Quarter			
Grid Points	IGA Annual Leq (24)	Calculated Leq (24)	Difference Leq	Grid Points	IGA Annual Leq (24)	Calculated Leq (24)	Difference Leq
A,1	38.6	40.6	2.0	C,4	44.2	41.1	-3.1
A,2	37.6	41.3	3.7	C,5	36.7	38.1	1.4
A,3	42.3	42.5	0.2	C,6	36.0	36.2	0.2
A,4	45.3	43.3	-2.0	D,4	41.1	39.6	-1.5
A,5	43.9	44.9	1.0	D,5	34.2	37.0	2.8
A,6	37.5	46.1	8.6	D,6	36.0	35.5	-0.5
A,7	37.7	46.0	8.3	D,7	41.4	37.2	-4.2
A,8	36.5	43.7	7.2	E,4	38.3	39.7	1.4
A,9	36.3	41.1	4.8	E,5	34.8	38.7	3.9
A,10	37.6	40.2	2.6	E,6	36.7	36.3	-0.4
A,11	39.2	39.6	0.4	E,7	41.4	36.3	-5.2
A,12	41.2	39.4	-1.8	F,2	51.7	47.3	-4.5
B,2	39.5	42.0	2.5	F,3	43.7	44.5	0.8
B,4	42.5	44.0	1.5	F,5	37.3	38.1	0.8
B,5	43.1	45.6	2.5	F,6	38.5	37.5	-1.0
B,6	39.0	47.1	8.1	F,7	42.1	37.7	-4.4
B,7	39.0	46.7	7.7	G,2	51.2	49.1	-2.1
B,8	38.0	43.6	5.6	G,3	42.1	45.6	3.5
B,9	38.3	41.6	3.3	G,4	40.2	40.3	0.1
B,10	39.0	41.2	2.2	H,2	50.1	50.9	0.8
B,11	40.4	40.8	0.4	H,3	46.0	46.4	0.4
B,12	42.6	40.5	-2.1	H,4	46.1	40.6	-5.5
C,2	41.0	42.7	1.7				
C,3	43.3	44.1	0.8				
C,4	43.5	44.9	1.4				
C,5	43.4	46.5	3.1				
C,6	43.3	48.2	4.9				
C,7	43.3	47.2	3.9				
C,8	42.6	43.9	1.3				
C,9	42.2	42.5	0.3				
C,10	41.6	42.7	1.1				
C,11	42.5	42.3	-0.2				
C,12	44.3	41.8	-2.5				
D,2	41.7	43.2	1.5				
D,3	46.2	44.8	-1.4				
D,4	48.4	45.9	-2.5				
D,5	48.2	47.4	-0.8				
D,6	46.2	49.5	3.3				
D,7	44.2	47.7	3.5				
D,8	43.7	44.4	0.7				
D,9	43.1	44.3	1.2				
D,10	44.9	44.0	-0.9				
D,11	44.5	43.2	-1.3				
D,12	45.1	42.6	-2.6				
E,1	42.4	42.5	0.1				
E,2	42.2	43.6	1.4				
E,3	46.7	45.5	-1.2				
E,4	51.2	47.1	-4.1				
E,5	51.0	48.6	-2.4				
E,6	44.6	50.9	6.3				
E,9	43.1	45.8	2.7				
E,10	43.1	44.3	1.2				
E,11	46.1	43.4	-2.7				

Area 3 3rd Quarter			
Grid Points	IGA Annual Leq (24)	Calculated Leq (24)	Difference Leq
A,-1	38.9	36.9	-2.0
A,0	39.6	37.0	-2.6
A,1	43.2	37.7	-5.5
A,2	45.7	39.4	-6.3
A,3	45.6	41.0	-4.6
B,-1	37.9	36.4	-1.5
B,0	39.2	36.4	-2.8
B,1	42.6	37.2	-5.4
B,2	45.8	38.9	-6.9
B,3	45.7	41.1	-4.6
C,-1	36.7	36.6	-0.1
C,0	37.1	36.6	-0.5
C,1	39.5	37.2	-2.3
C,2	44.8	38.9	-5.9
C,3	46.5	41.4	-5.1
D,-1	32.6	37.2	4.6
D,0	33.3	37.3	4.0
D,1	37.3	37.6	0.3
D,2	43.0	38.9	-4.1
E,-1	31.4	37.7	6.3
E,0	33.1	37.4	4.3
E,1	36.2	37.7	1.5
E,2	40.6	38.9	-1.7
F,1	36.5	37.6	1.1
F,2	39.4	39.4	0.0
G,1	42.5	38.4	-4.1

Runway Utilization – Third Quarter 2000

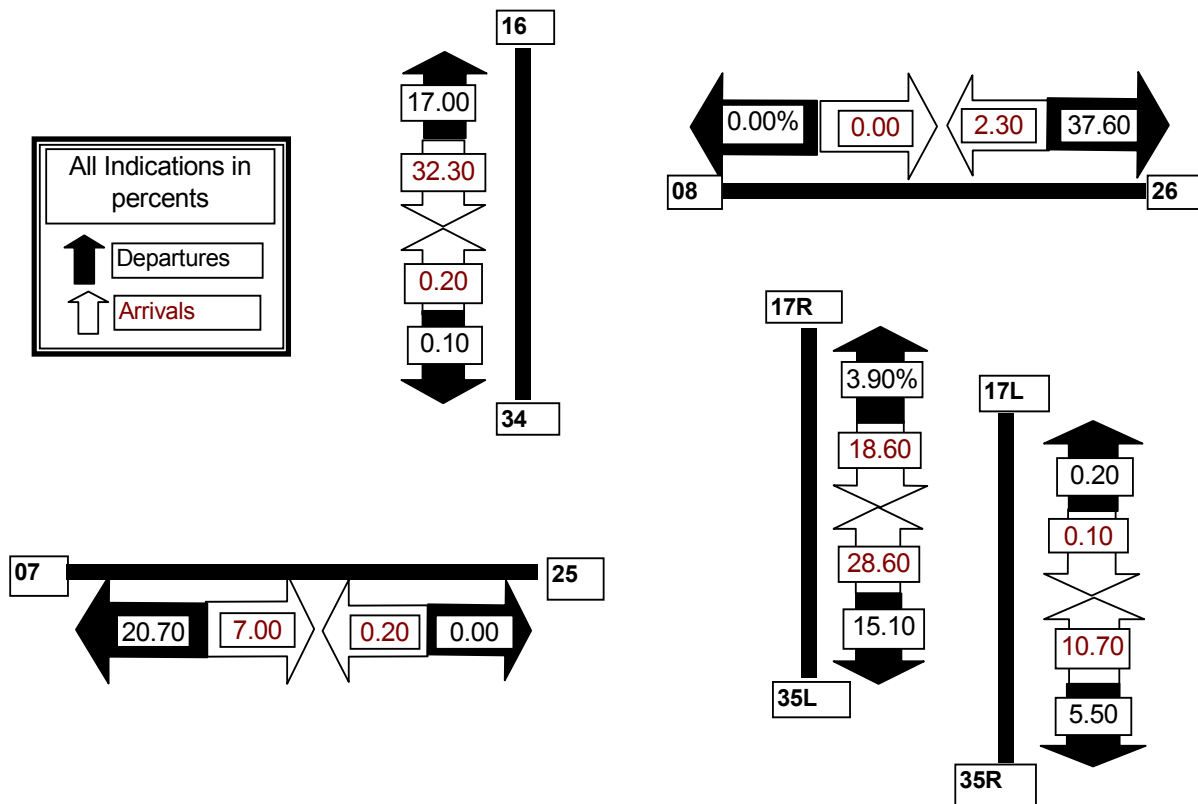

Day Arrivals (700am-959pm)

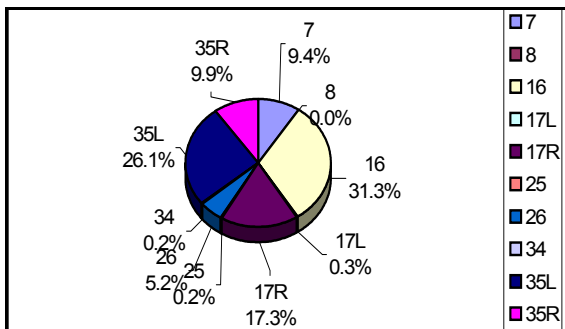

Day Departures (700am-959pm)

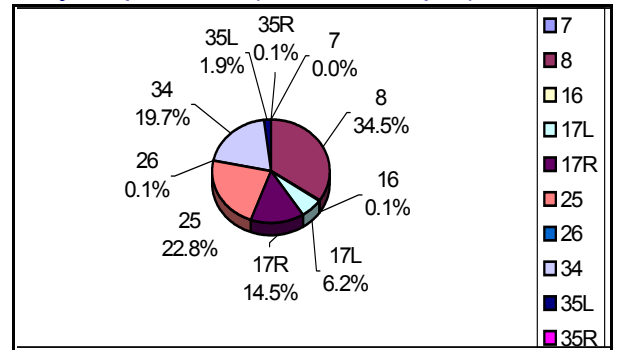

Night Arrivals (1000pm-659am)

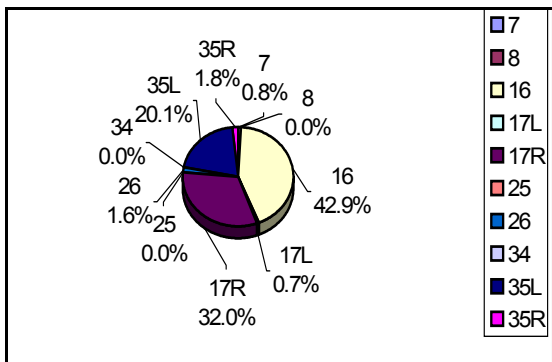

Night Departures (1000pm-659am)

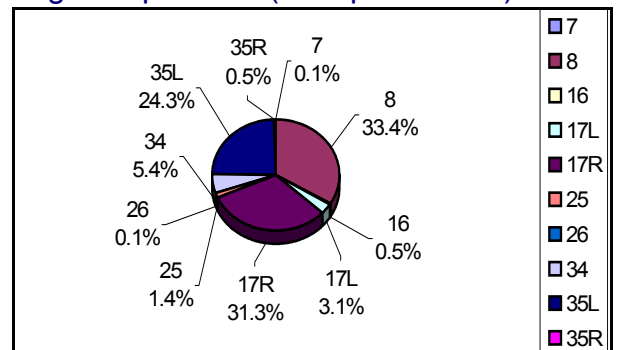

Fourth Quarter, 2000

December 1, 2000 – February 28, 2001

Fourth Quarter 2000 65 Ldn Contour

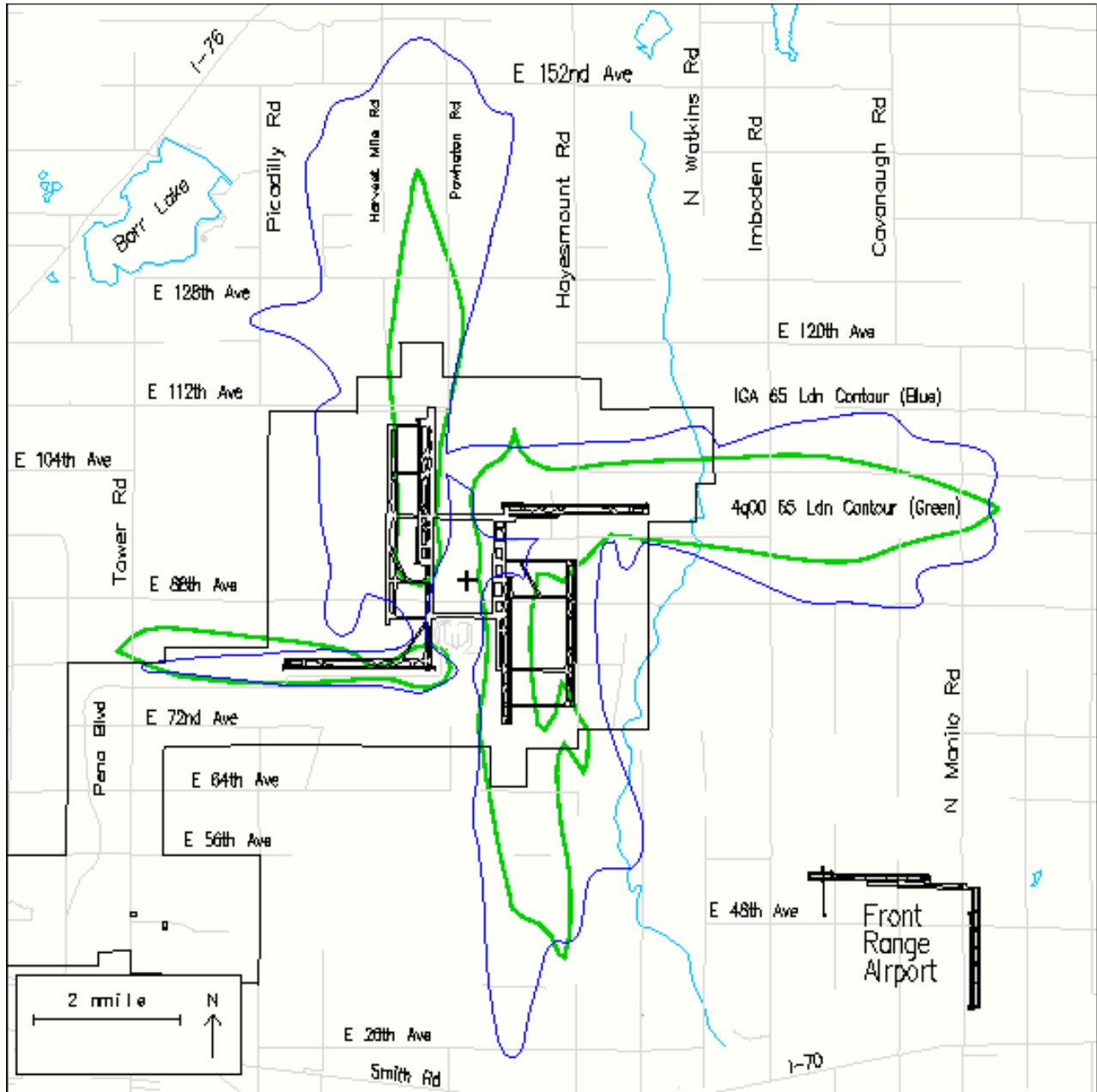

Denver/Adams County IGA NEPS Values – Fourth Quarter 2000

Area 2				Area 1			
Grid Points	4th Quarter		Difference	Grid Points	4th Quarter		Difference
	IGA Annual Leq (24)	Calculated Leq (24)			IGA Annual Leq (24)	Calculated Leq (24)	
A,1	38.6	39.3	0.6	C,4	44.2	39.9	-4.3
A,2	37.6	40.0	2.4	C,5	36.7	37.5	0.8
A,3	42.3	40.8	-1.5	C,6	36.0	35.9	-0.1
A,4	45.3	41.9	-3.4	D,4	41.1	38.0	-3.2
A,5	43.9	43.5	-0.4	D,5	34.2	36.2	2.0
A,6	37.5	44.5	7.0	D,6	36.0	35.5	-0.5
A,7	37.7	44.3	6.6	D,7	41.4	37.1	-4.3
A,8	36.5	42.2	5.7	E,4	38.3	38.3	0.0
A,9	36.3	39.4	3.1	E,5	34.8	38.8	4.0
A,10	37.6	38.1	0.5	E,6	36.7	36.6	-0.2
A,11	39.2	37.5	-1.7	E,7	41.4	36.3	-5.1
A,12	41.2	36.6	-4.6	F,2	51.7	45.2	-6.5
B,2	39.5	40.6	1.1	F,3	43.7	41.6	-2.1
B,4	42.5	42.5	0.0	F,5	37.3	38.3	1.0
B,5	43.1	44.2	1.1	F,6	38.5	38.2	-0.3
B,6	39.0	45.5	6.5	F,7	42.1	38.2	-3.9
B,7	39.0	45.0	6.0	G,2	51.2	47.1	-4.1
B,8	38.0	42.3	4.3	G,3	42.1	42.6	0.5
B,9	38.3	40.0	1.7	G,4	40.2	39.7	-0.5
B,10	39.0	39.3	0.3	H,2	50.1	49.1	-1.0
B,11	40.4	38.9	-1.5	H,3	46.0	43.3	-2.8
B,12	42.6	38.2	-4.4	H,4	46.1	40.2	-5.9
C,2	41.0	41.7	0.6	Area 3			
C,3	43.3	42.2	-1.1				
C,4	43.5	43.3	-0.2	4th Quarter		Difference	
C,5	43.4	44.9	1.5	Grid Points	IGA Annual Leq (24)	Calculated Leq (24)	Leq
C,6	43.3	46.6	3.3	A,-1	38.9	35.7	-3.2
C,7	43.3	45.5	2.2	A,0	39.6	35.9	-3.7
C,8	42.6	42.5	-0.1	A,1	43.2	36.6	-6.6
C,9	42.2	41.0	-1.2	A,2	45.7	38.2	-7.5
C,10	41.6	41.0	-0.6	A,3	45.6	39.8	-5.8
C,11	42.5	40.7	-1.9	B,-1	37.9	34.9	-3.0
C,12	44.3	39.8	-4.5	B,0	39.2	34.8	-4.4
D,2	41.7	42.5	0.8	B,1	42.6	35.4	-7.2
D,3	46.2	43.4	-2.8	B,2	45.8	37.4	-8.4
D,4	48.4	44.3	-4.1	B,3	45.7	39.7	-6.0
D,5	48.2	45.9	-2.3	C,-1	36.7	34.6	-2.1
D,6	46.2	47.7	1.5	C,0	37.1	34.5	-2.6
D,7	44.2	45.9	1.7	C,1	39.5	35.3	-4.2
D,8	43.7	42.9	-0.9	C,2	44.8	37.5	-7.3
D,9	43.1	42.8	-0.4	C,3	46.5	40.0	-6.5
D,10	44.9	42.6	-2.3	D,-1	32.6	35.1	2.5
D,11	44.5	41.8	-2.7	D,0	33.3	35.0	1.7
D,12	45.1	40.8	-4.3	D,1	37.3	35.8	-1.5
E,1	42.4	42.2	-0.2	D,2	43.0	37.7	-5.3
E,2	42.2	43.1	0.9	E,-1	31.4	35.8	4.4
E,3	46.7	44.4	-2.3	E,0	33.1	35.5	2.4
E,4	51.2	45.6	-5.6	E,1	36.2	35.8	-0.4
E,5	51.0	47.1	-3.9	E,2	40.6	37.8	-2.8
E,6	44.6	49.1	4.5	F,1	36.5	36.0	-0.5
E,9	43.1	44.5	1.4	F,2	39.4	38.2	-1.2
E,10	43.1	43.6	0.5	G,1	42.5	36.1	-6.4
E,11	46.1	42.3	-3.8				

Runway Utilization - 4th Quarter 2000

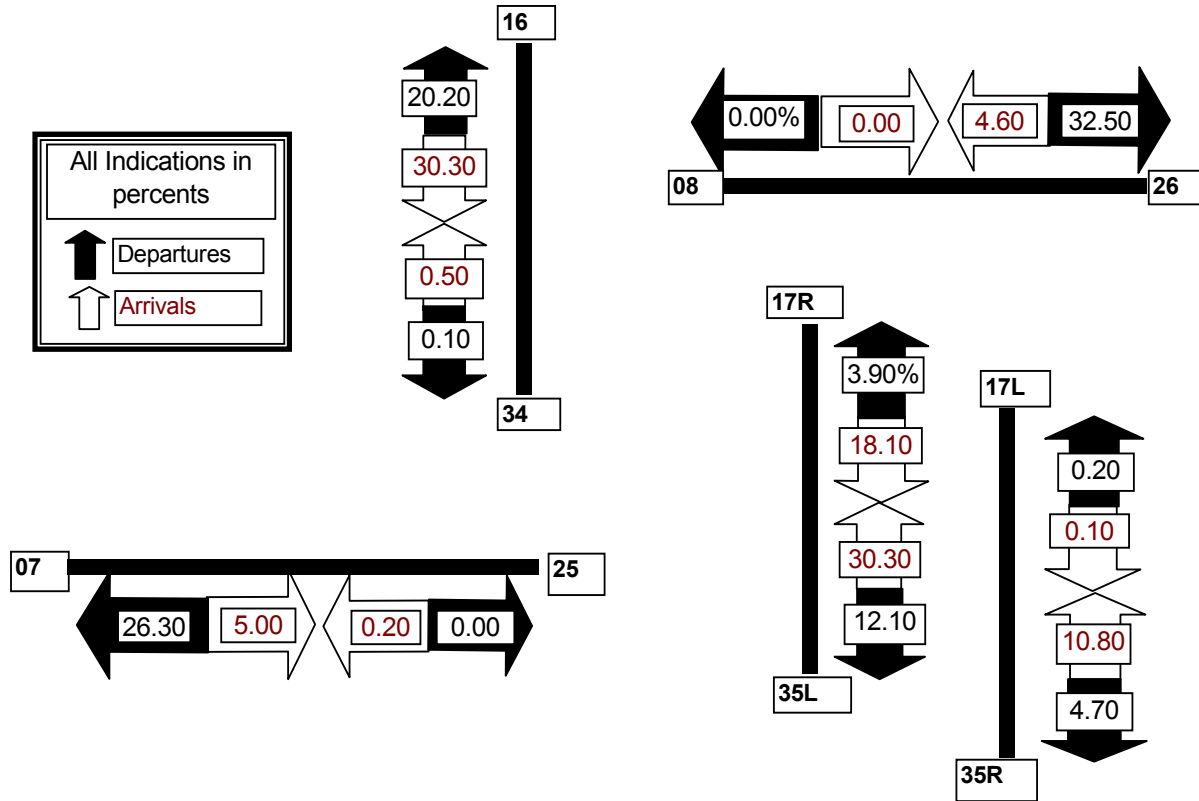

Day Arrivals (700am-959pm)

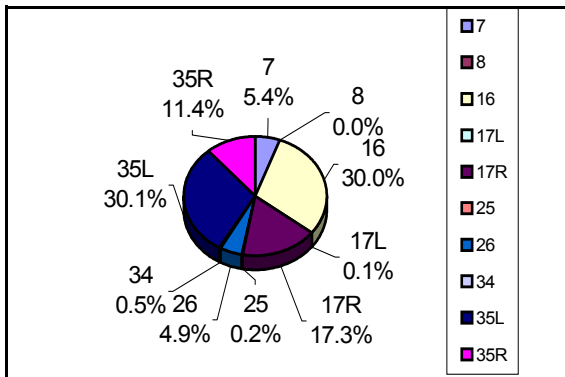

Day Departures (700am-959pm)

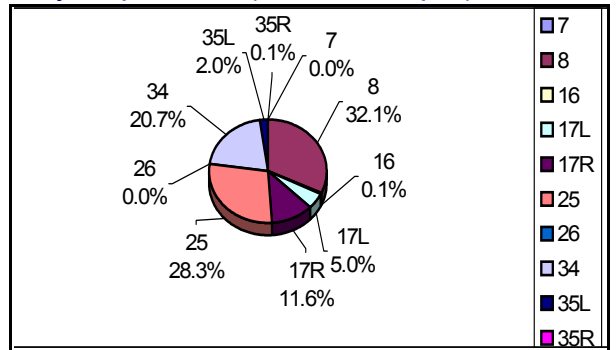

Night Arrivals (1000pm-659am)

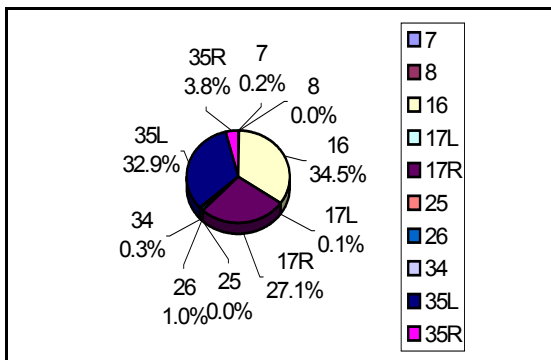

Night Departures (1000pm-659am)

